



CTR 2000

FULLY AUTOMATIC STRETCH WRAPPER

CYKLOP[®]
GLOBAL PACKAGING SOLUTIONS

STRAPPING
WRAPPING
CODING
TAPING

This CTR 2000 has been developed to meet ever tougher demands from the industry. The wrapper is fast, yet flexible and can handle varying types of goods, including goods not covering the whole pallet.

Four individual wrapping programmes for different types of goods have been pre programmed and can be chosen manually from the operating panel or by remote control from adjacent equipment. Individual settings for every programme can easily be made by the user in the display unit. No previous knowledge of programming or special equipment required to make these settings. It is easy to calculate the cost of the film. The amount used for each pallet application is shown on the display.

The CTR 2000 has a unique system with a battery-powered film unit which means that the ring does not have a rotating power-feed, rendering the system practically maintenance-free. Recharging always takes place when the ring is in home position.

Easy to operate

- Controls are easy to find and understand.
- Fast and simple film roll change.
- Automatic load height sensor.
- Mechanics – designed for easy maintenance.

Saves money

- Pre-stretch ratio is adjustable up to 300%. **POWER ECOSTRETCH⁺**
- Motorized pre-stretch unit minimizes film consumption and protects delicate goods.
- The chosen pre stretch ratio stays constant, which guarantees consistent low film consumption, load after load.
- Film carriage speed is individually adjustable to optimize film overlap.

Key features

- Easy change of all program parameters and settings.
- All functions can be manually operated.

Consistent packaging result

- Flexible setting possibilities enable optimum packaging for a variety of goods.
- The film tension is automatically controlled which gives an even cover around the goods.
- Several standard programs are available, e.g. with top sheet for protection against water.
- 5 programs are factory preset.
- The memory can contain 15 programs, which all can be programmed with individual parameters.

The display can show the following information:

- Film consumption for the last pallet.
- Total number of wrapped pallets after latest reset.
- Film cost per pallet.
- Help with troubleshooting.



All program parameters and settings can easily be adjusted in the color touch display.

Options

Most options and accessories can be ordered for after market fitting. As a result of our strive to improve our products, the information and specifications are subject to change without prior notice. Below is a selection of available options:

- Higher machine for pallet loads up to 3000mm
- Pallet check in/out conveyor, photocells for control of in/out feeding side
- Pallet control, photocell for control of pallet size and position
- High speed ring
- TSD - Top sheet dispenser
- Welding with metal plates
- Corner protection applicator
- 90° degree in or out transport
- Air conditioned electrical cabinet
- Alarm "Film almost at an end"
- Extended ring for larger pallet loads
- Heightseeking device
- Lifting trolley for loading of stretch film roller*
- Lifting device for loading of top film roller TSD
- Lightbeams
- Stringroller
- Roping device
- Top plate, rectangular (600 x 1000 mm)
- eWon remote access
- Safety fence



The Cyklop CTR 2000 is a high performance wrapping machine, equipped with Cyklop's patented pre-stretch system **POWER ECOSTRETCH⁺** which is adjustable up to 300%.

Click on the QR code or scan it with your mobile camera to watch a video of CTR 2000 TWIN with Top sheet dispenser



Click on the QR code or scan it with your mobile camera to watch a video of CTR 2000 with corner protection applicator

Click on the QR code or scan it with your mobile camera to watch a video of film roller change with a Lifting trolley



*) The lifting trolley is a helpful tool when loading stretch film rollers into the CTR 2000.

Technical specifications		
Machine	Capacity	Up to 120 pallets/hour
	Pre-stretch system	POWER ECOSTRETCH⁺
	Pre-stretch ratio	7 steps up to 300%
	Stretch wrapping programs	15 with fully adjustable parameters
	Motors	Frequency controlled
	Protection	IP54
	EX-classification	Not approved for ATEX classified areas
	Operating temperature	1-35°C (34-95°F) for use in a dry, tempered area
Power	Supply	3-phase 400 V+N+PE, 50 Hz
	Load	5,3 kW (7,2 kW with TSD & top plate)
	Fuse	20A (for 5,3kW) / 25A (for 7,2kW)
	Controller	Siemens PLC S7
	Battery	48V
Pneumatics	Supply	6 bar, approx 18 NL/cycle
Pallet goods	Max size (LxW)	1200x1000mm / 1000x1400mm
	Height incl. pallet	500-2400mm*
	Max weight	Unlimited (depends on conveyor capacity)
	Roll weight	max. 40 kg
Stretch film	Film width, max	500mm
	Film thickness, max	9-35my
	Core diameter	76mm
	Outer roll diameter, max	250mm

*) When transport height is 400mm.

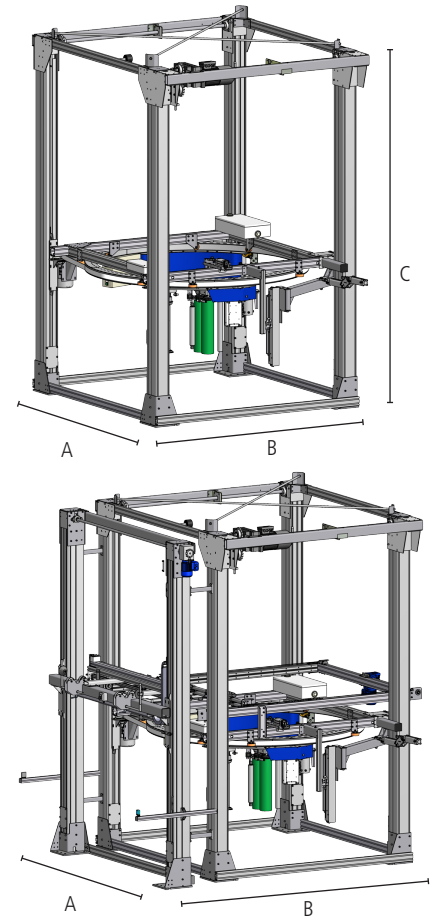

Dim (mm)	A	B	C
Standard	2800	2400	3780
With TSD	2800	3200	3780

Crated dimensions std machine:
L3800 x W2400 x H2850 mm, weight 2000 kg.

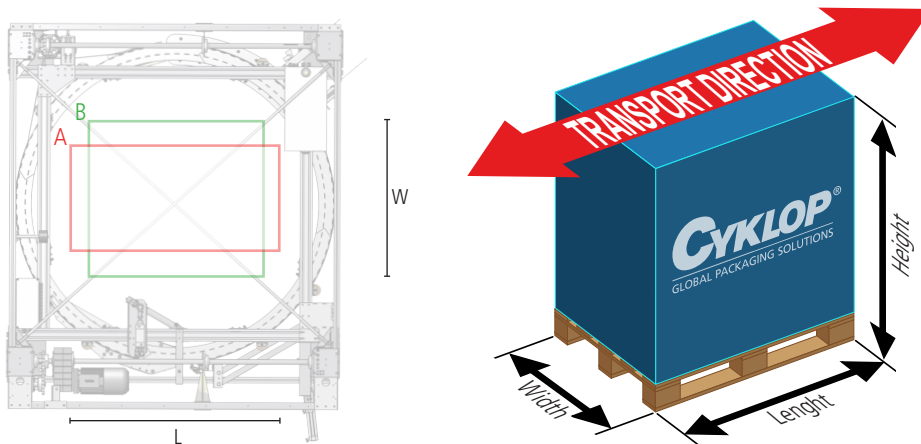

Dimensions	Length	Width	Height Std*	Height with TSD*	Height with top plate*	Height with TSD+top plate*	Weight
Pallet, min	400mm	600mm	500-2400mm	750**-2150mm	500-2400mm	750**-1900mm	>100kg
Pallet type A, max	1400mm	1000mm					
Pallet type B, max	1200mm	1200mm					

*) When transport height is 400mm.

**) Lower pallets are possible but we then recommend adding a lifting table for best results.

Cyklop AB
Tellusgången 3
126 26 Hägersten

08 503 053 00
www.cyklop.se
info@cyklop.se

